

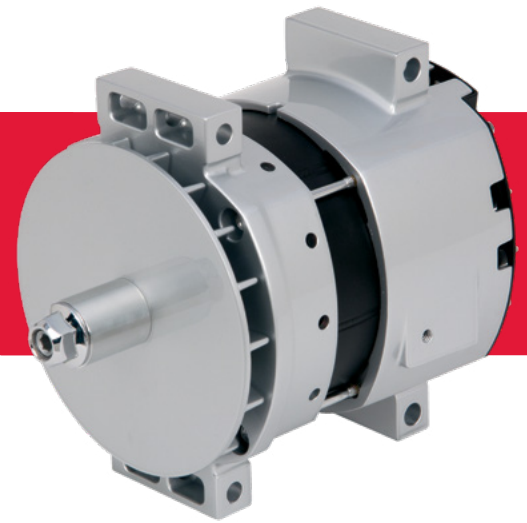

38SI™

HEAVY DUTY BRUSHLESS ALTERNATOR



HIGH EFFICIENCY = FUEL ECONOMY

Go to delcoremy.com to calculate your savings when you install a 38SI.

FEATURES & BENEFITS

- **Brushless Advantage:** fewer moving parts means less wear and longer life
- **Equipped with Remote Sense** which can reduce battery charge time by 50%

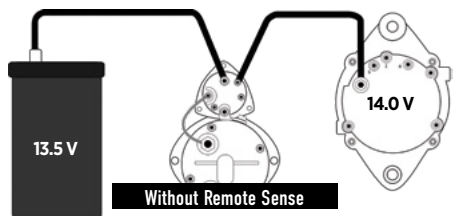
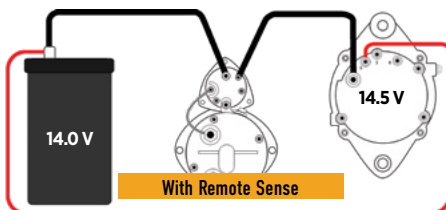

Remote Sense utilizes a second wire that reads the actual voltage at the battery. This signals the alternator to boost its output to compensate for the voltage drop, ensuring 14 Volts at the battery. The proper voltage forces more current into the battery bringing it to a full state of charge between vehicle stops.

- **OE approved,** assuring OE quality and performance for aftermarket replacements
- **Superior output** producing up to 215 Amps at road speed and 121 Amps at idle
- **Warranty:** 3 year/unlimited miles (Applicable to U.S. and Canada only)

High efficiency translates to less engine horsepower requirements, resulting in substantial fuel savings.

Real time operating data was collected on several vehicle applications for the overall vehicle and electrical system. The following chart shows the fuel cost savings over a typical life cycle by increasing the alternator efficiency from 60% to 72%.

FUEL SAVINGS

VEHICLE TYPE & MILES DRIVEN	AVERAGE CURRENT	FUEL COST WITH A 60% EFFICIENT ALTERNATOR	FUEL COST WITH A 72% EFFICIENT ALTERNATOR (40SI)	SAVINGS
Line Haul Tractor (500k mi)	84 Amps	\$4,534	\$3,778	\$756
City Tractor (350k mi)	40 Amps	\$2,235	\$1,863	\$372
School Bus (250k mi)	102 Amps	\$9,040	\$7,533	\$1,057

Based on diesel fuel at \$4/gal

SPECIFICATIONS

Performance Output	12V/215 Amps (121 Amps at idle)
Maximum Speed	8,000 RPM Continuous; 10,000 RPM Intermittent
Rotation	Clockwise
Temperature Rating	130°C/266°F
Mounting	Pad Mount
Efficiency	72 %
Weight	30.4 lbs/13.8 kg
Stator Diameter	5.98 in/152 mm
Length	9.99 in/253.8 mm

38SI™ HEAVY DUTY BRUSHLESS ALTERNATOR

COMPETITIVE COMPARISON

SPECS	DELCO REMY 38SI	LEECE NEVILLE
Temp. Rating	130°C/266°F	125°C/257°F
Average Efficiency	72%	62%
Max Output	215 Amps	200 Amps
Stator Diameter	5.98 in/152 mm	6.61 in/168 mm
Length	9.99 in/253.8 mm	11 in/280 mm
Remote Sense	Standard	Optional

COMPETITIVE INTERCHANGE DATA

MOUNTING	PART #	OUTPUT (AMPS)	PART #	SALES #	OUTPUT (AMPS)
	DELCO REMY 38SI		LEECE NEVILLE		
Pad	8600707	215	BLP2362GH	BLD/P	200
			BLP2357GH	BLD/P	
			Melco/Mitsubishi		
			AM0071	A200	200
			Bosch		
			AL9962SB	Long Haul	200
AL9921LL	Long Haul Extreme	200			

38SI 12V POWER CURVE

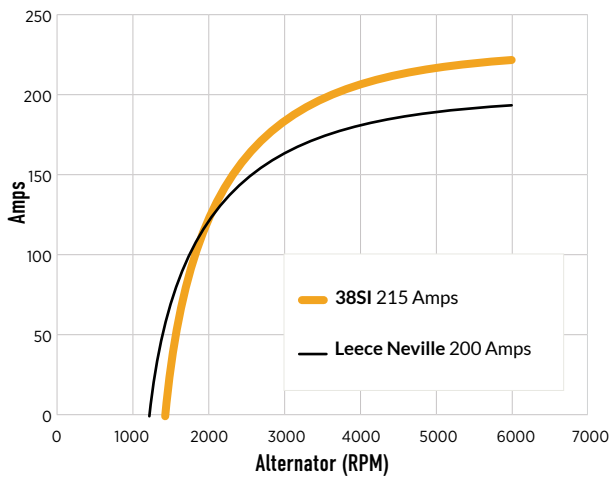

INSTALLATION

- Ground Screw (-)
- Indicator/Ignition
- Remote Sense
- Battery (+)
- Relay

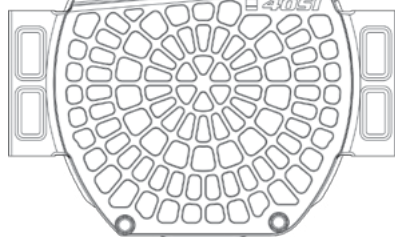

38SI™

NOTE: When the Remote Sense terminal is not connected, the alternator operates and regulates voltage normally.

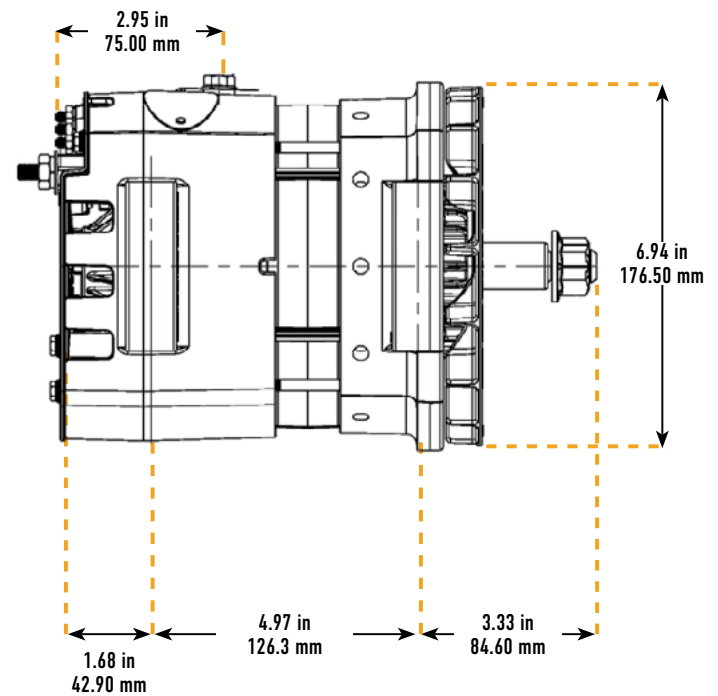

For Customer Service or Technical Assistance call 800-372-0222

01 | 2024
DELCOREMY.COM